

Introduction

SCOPE, APPLICATION AND FUNDAMENTALS OF CHEMICAL ANALYSIS

Analysis of soil, plant, and water followed by adopting remedial measures based upon the results of their analysis wherever warranted are central to performing remunerative, intensive, and sustainable agriculture. Their analysis viz. of soil, plant, and water, forms the core interest of this book. The analysis of a substance regardless of whether it is a natural resource such as the soil and water, or of biological origin such as plants or manures, or a synthetic one such as a fertilizer or pesticide comes under the domain of the subject of analytical chemistry. Analysis of soil, plant, and water therefore can not be dealt with a holistic approach without comprehending the pre-required basics and fundamentals of the subject of its origin *i.e.* analytical chemistry. This section deals with understanding the significance of the subject of analytical chemistry and the primary approaches, techniques, and methods followed in pursuit of the subject.

Analytical chemistry is a branch of chemistry and is all about ascertaining the composition of matter. The term ‘matter’ in the context stands for a great myriad of materials that includes natural resources such as the crude petroleum or an ore that we unearth for extracting a metal or the ground water we use or even the air we breathe in, or the man made ones such as the fertilizers used for growing plants, cosmetics and toiletries in our daily life, textiles for clothing, medicines and pharmaceuticals for health, packaged fast food and mineral water we eat and drink and countless more. It is intriguing to ask whether they do really contain what they should. Is it that their compositions have been manipulated deliberately or they have undergone changes either inadvertently or even accidentally? How do we be sure? Do they contain any spurious, substandard and ‘not permitted’ agent - may be the food preservative or a colouring agent in a fast food or hair dye or skin toning agent - to enhance their marketability and shelf storage? Do they contain any unsafe ingredient and if so, then what is the ingredient and what is its content? Is its use permitted by statutory and regulatory agencies? If permitted, is the content below the permissible limit prescribed by such authorities? Is our dairy milk contaminated by pesticides or are we relishing the fish that has actually been poisoned by mercury? Does my mineral water in the PET bottle really contain any mineral or is it contaminated with a radio isotope or heavy metals or pesticide? Does the fast food noodle in tetra pack that the children are so crazy contain any ‘not permitted’ flavor enhancing agent or any heavy metal, say lead or arsenic? Is it that the champion athlete resorted to

taking a banned anabolic steroid to enhance his performance? Does the urea stockpiled in the fertilizer godown contain the guaranteed content of nitrogen? Are the levels of the phytotoxic biuret and moisture that may help form a hard cake in damp weather below the maximum permissible limits? Does the product destined for export conform to the set standards? Does the air we are breathing contain enough of asbestos, a silent killer? These questions shall remain unanswered until the compositions of the substances are checked by their chemical analysis. Also, the questions posed amply demonstrate the importance of the subject of analytical chemistry. Taking a deeper dig, these questions also imply two fundamental quality aspects of a commercially available material *i.e.* the latter must contain one or more than one ingredient at not less than a preset level and must not contain one or more than one ingredient at not more than a preset level. Taking the case of urea, the fertilizer grade material must by normal standards must contain not less than 46% (w/w) nitrogen and must not contain more than 1.5 and 1.00% (w/w) biuret and moisture, respectively. Stated in very simple terms, urea available in the market for fertilizer use must adhere to a specified composition. But, how does one be sure about this adherence to the specified composition of a product? It is in this context the domain of the subject of analytical chemistry comes into play.

With this background in hand, we can now define the term ‘analytical chemistry’. Analytical chemistry is the branch of chemistry concerned with the determination of chemical composition of substances. Ascertaining the composition of a substance has been a daunting issue for man since long for a variety of reasons, and very justifiably, therefore, analytical chemistry has been one of the oldest branches of chemistry and has been in practice since the days of alchemy, though it may be so in its crude rustic form. For a fairly long period however, the subject consequent to being practiced in crude form was largely empirical and not supported by strong theoretical principles. Modern analytical chemistry with a strong foundation on theoretical background commenced its run in the nineteenth century when the theories on various subjects like the combustion, electrical circuitry, electrolysis, solution, gas laws, pH, the Law of Mass Action, chromatography, and spectroscopy were elucidated. Since then there has been rapid progress and today analytical chemistry is one of the most developed branch of chemistry.

The laboratory segment of the subject of analytical chemistry too has undergone a quantum improvement in the last few decades. The days are over when the analysts used to be bogged by daunting hours of painstaking exercises involved in pipetting, filtration, digestion, distillation, and weighing in traditional balances. Today, even ordinary laboratories are using automatic pipettes for volume dispensation, vacuum pumps to hasten up filtration and distillation, automatic pipette washers, and many digital devices – just to quote a few. Many traditional analyses are performed by instrumentation with results displayed in a couple of seconds with a print out in hand. In sophisticated analytical chemistry laboratories, today many things go by the click of a mouse of the computer and the results reach the analysts in no time. Increasing demand for more

accurate and quicker results of analysis provided the necessary impetus for all these developments to be a reality.

The frontiers of the subject of analytical chemistry have been greatly extended in the recent past, so much so that the subject is no longer the forte of analytical chemists alone. A case in support is the elucidation of the structural configuration of substances, a field wherein persons of other branches of chemistry and even those of physics and allied fields have to join the investigating team. Today analytical chemistry is no more the arena of analytical chemists working alone within a protected enclosure. The subject of analytical chemistry because of its vastness and extensive ramifications is now thrown open to all concerned; indeed, the subject has been the converging point for several other subjects as well. Nonetheless, the major focus of the subject of analytical chemistry revolves round the establishing the chemical composition of substances. Very justifiably therefore, the subject does have a huge applied value. There is virtually none in without being a stake-holder of the subject either in a direct or an indirect way. All industrial establishments irrespective of whether they are agrobased or metallurgical units, hospitals, health check-up and clinical facilities, and environment monitoring and regulatory agencies must run with a strong analysis and quality control laboratory donned by competent analytical chemists, the principal tasks of which are quality check of the products, diagnosis of the disease or disorder for the right course of treatment, and keeping a regulatory vigil on the contamination of the components of the environment such as the water, soil, and air. There are thousands and thousands of substances to be analysed, even if they are dealt under classified categories viz. fertilizers, heavy metals, food preservatives, hydrocarbons, detergents, sugars, steroids etc. The list indeed runs into millions and no single book can cover the bench works of the analysis of all of them. This book is aimed at familiarizing the theory, principles, and the methods involved in the analysis of soil, plant, and water, primarily as far as they are concerned with a clean and bountiful agriculture.

1.1 Two Major Divisions of Analytical Chemistry

The two major divisions of the subject of analytical chemistry are

1. Qualitative analytical chemistry, and
2. Quantitative analytical chemistry

The objective of qualitative analytical chemistry is to find out the different chemical constituents that together constitute the substance, while that of quantitative analytical chemistry is to ascertain what fraction of each such constituent constitutes the substance. Normally, in establishing the composition of an altogether new substance in the laboratory, the qualitative analysis must precede the quantitative analysis. This is primarily because the protocol and methodology to be set in for quantitative assay are to be selected based on the results of the qualitative analysis. For elemental composition for instance, the first task is to work out the elements that constitute the substance. A carbon

analyzer is not required in case carbon is not a constituent of the unknown substance; conversely, an atomic absorption spectrophotometer is to be readied with an appropriate hollow cathode lamp, if mercury is a constituent of an environmental analysis. However, in dedicated chemical analysis laboratories like those for soils, fertilizers, pesticides, water, medicines and pharmaceuticals etc., qualitative analysis is normally not warranted.

Both qualitative and quantitative analysis require specific chemical reactions or transformations by addition of appropriate reagents, since in order to recognize a substance or a particular chemical constituent present in the substance, one must often chemically alter the substance. This implies that the sample undertaken for analysis is chemically lost during the course of the analysis. This is indeed a great impediment in doing the analysis of samples available in very minute quantities. However, a number of nondestructive methods of analysis based mostly on automotive instrumentations are now available. *Par se* accuracy and reproducibility of the results of the majority nondestructive methods are however, often debated.

1.1.1 Qualitative Analysis

In qualitative analysis, only such reactions are made used of as are perceptible to our senses of recognition viz. the formation of a precipitate, the formation or the change of colour, the characteristic shape of the crystals formed, and the evolution of a gas that can be observed by its characteristic colour. In other words, the sense of sight is of paramount importance in analytical chemistry, since in many chemical assays, the results of the reactions employed are judged by visual results. The sense of smell may help further, since many of the reaction products are vapours or are highly volatile and emit a typical characteristic odour. However, owing to toxic nature of some of these gases or vapours (such as hydrogen cyanide, bromine, sulfur dioxide, hydrogen chloride, and ammonia), the detection by sense of smell is strongly discouraged. In the early days of analytical chemistry, the sense of taste was also utilized. For instance, the acids were characterized by their sour taste. The sense of taste however, is never recommended for reasons of toxic nature of many substances. The sense of feel by touch was also useful earlier in identifying a substance. For instance, graphite gives a characteristic greasy touch. Identifying a substance by the sense of touch is also never recommended for the same reasons of associated danger as in the case of smell and taste.

Substances to be characterized in a laboratory may be either organic or inorganic. Although, many of the methodologies employed in their characterization are common to both, the general method of approach is typically different for organic and inorganic substances. Further, in either case, there are thousands of different substances and each substance by its complete nature is unique and is different from others. It is just not possible to have an exclusive method for each of the substances. Therefore, for qualitative analysis substances are to be categorized into a small number of similar groups. The first task in the direction is to characterize a substance as an organic or inorganic substance.

Simple properties and tests like water insolubility, solvency in or miscibility with organic solvents, low boiling and melting points, low dielectric constants etc. generally prove to be sufficient for a substance to be characterized as an organic substance. For further narrowing down, the organic compounds are characterized into relatively smaller classes by their functional groups. A functional group of an organic compound is a very small part of the molecule comprising a single atom or a small group of atoms; this small part of the molecule constitutes the reactive and the determinate part of the molecule, while the rest of the large molecule is not of much consequence in determining the properties of the compound. For example, if formic acid (HCOOH) is warmed with absolute ethanol and concentrated sulfuric acid (1:2:1) for two minutes, the mixture is cooled, and then made alkaline by the addition of a weak base like sodium carbonate, a substance with a fruity smell is formed. A similar result is obtained with acetic, propionic, and benzoic acid (CH_3COOH , $\text{CH}_3\text{CH}_2\text{COOH}$, $\text{C}_6\text{H}_5\text{COOH}$). It is thus apparent that organic substances with a carboxyl functional group (COOH) can be characterized by this taste. In this case, the carboxylic acids reacted with ethanol to form their esters viz. ethyl formate, ethyl acetate, ethyl propionate, and ethyl benzoate. Most esters do have a fruity smell. Likewise, all carbonyl compounds (aldehydes and ketones) react with 2,4-dinitrophenylhydrazine to form a sparingly soluble crystalline precipitate of 2,4-dinitrophenylhydrazone. Therefore, if an organic substance performs a positive phenylhydrazine test, the substance may be inferred to be an aldehyde or a ketone. In this way, in qualitative analytical chemistry, the organic compounds are characterized based on their functional groups.

Inorganic compounds unlike the organic ones do not have functional groups. However, a great majority of them do have two distinct structural moieties with opposite charges viz. a cation (+ve) and an anion (-ve). Chloride, sulfate, nitrate, phosphate, carbonate, cyanide, ferrocyanide are all anions, while ammonium and metal ions like sodium, potassium, magnesium etc. are all cations. Inorganic compounds are accordingly categorized based on their anions and cations viz. chlorides, sulfates, phosphates, sodium salts, iron salts etc. If one finds the cation to be ammonium and the anions to be sulfate and nitrate, the substance must be a mixture, and the mixture or the double salt must be made up of ammonium nitrate and ammonium sulfate.

Obviously, the quantitative analysis of most unknown inorganic compounds commences with the characterization of the cations and anions present in them, since they together constitute the whole substance. When an aqueous solution of BaCl_2 is added to a dilute solution of H_2SO_4 , a white crystalline precipitate of BaSO_4 is formed. Also, a precipitate of identically the same composition is formed by adding BaCl_2 to a solution of any soluble sulfate instead of H_2SO_4 . It therefore may be inferred that all soluble sulfates form a white precipitate with BaCl_2 , and the test becomes a generalized test for an inorganic substance with sulfate as the anion or one of the anions. In the same way, the property of a substance to react with AgNO_3 solution to form a white precipitate and dissolution of the precipitate by dilute NH_3 confirms the substance to be a chloride

containing one. If on the other hand, the substance in the flame test exhibits an orange coloured flame, calcium (Ca^{2+}) must be the cation or one of the cations; if however, in the same test, the flame exhibits a blue or bluish green colour, the cation part is ought to be copper (Cu^{2+} or Cu^+).

If the substance to be dealt for analysis is completely unknown, then with such initial leads obtained in qualitative analysis, one has to move over to quantitative analysis.

1.1.2 Quantitative Analysis

In comparison to qualitative analysis, quantitative analysis requires more labour, time, and expertise, and also much greater accuracy and reproducibility of the results. The three basic aspects of quantitative analytical chemistry are

1. Drawing truly representative samples, their processing, and storage,
2. Analysis of the samples, and
3. Interpretation of the results of analysis.

Quantitative analysis commences with drawing a small and yet truly representative sample from the whole lot. Sampling is presumably the most important segment in quantitative analytical chemistry. For majority of the materials available in trade channels such as fertilizers, pesticides, medicines and pharmaceuticals, cements and building materials, food grains, animal feeds, processed foods, food preservatives, cosmetics and allied consumer needs, and those of public interests such as soils, water, and air, the methods, the guidelines, and the 'dos' and 'do nots' of drawing representative samples, and their processing and storage are now well defined and documented by various Government, Regulatory, and Statutory authorities such as Bureau of Indian Standards, Food and Agriculture Organization etc.

Once the representative sample has been drawn very faithfully, the task in hand is their analysis. For analysis, a large number of methodologies are available for use. The principles of some of these methodologies that are in frequent use are described in brief.

1.2 Common Methods in Quantitative Analysis

1.2.1 Gravimetry

Determination by recording the weight of an insoluble substance formed during the course of the analysis and relating the weight so recorded to the purity of the substance that is being determined forms the basic principle of gravimetric analysis. In most gravimetric analysis, the substance to be determined is chemically altered by the formation of a sparingly soluble substance, say by precipitation, and the sparingly soluble substance containing the constituent to be determined is separated from the solution by

filtration. The following scheme of operation is generally followed for a gravimetric analysis.

A representative sample → precipitation by chemical treatment → separation of the precipitate, say by filtration → drying or ignition of the precipitate → cooling and weighing of the dried or ignited precipitate → calculation of purity of the substance being determined by using appropriate conversion factor.

Say, for instance CaCO_3 content of a limestone sample is to be determined by gravimetric method. Limestone being water insoluble needs to be dissolved, a task accomplished by adding a mineral acid. A known weight of the sample of limestone is thus dissolved by adding dilute HCl and then after pH adjustment, ammonium oxalate solution is added for the formation of CaC_2O_4 (calcium oxalate) precipitate. The precipitate is separated out from the solution by filtration, washed repeatedly by water to make it free from the substances of the reaction medium adhering to it, dried, cooled, and then weighed very accurately. Finally the weight of the precipitate of CaC_2O_4 is related to the weight of CaCO_3 by means of the appropriate conversion factor. The sequence of operations for the determination of CaCO_3 (or Ca) content of a limestone sample are thus

Limestone (CaCO_3) sample (known weight)

↓ add dilute HCl

CaCl_2

↓ add $(\text{NH}_4)_2\text{C}_2\text{O}_4$ solution

CaC_2O_4 precipitate

↓

Filter, wash, dry and weigh the precipitate

↓

Determine CaCO_3 content by multiplying the weight of the precipitate by $\frac{100}{128}$

or, determine Ca content by multiplying the weight of the precipitate by $\frac{40}{128}$

Recording two accurate weights viz. of the sample (limestone) to be determined for purity and the precipitate (CaC_2O_4) formed are thus required. Note that limestone is the sample and not CaCO_3 ; during analysis, CaCO_3 in limestone sample has been chemically transformed to CaC_2O_4 . There are however, certain basic prerequisites to be maintained. Thus,

1. The precipitate to be separated and finally weighed after drying must be exceedingly water insoluble, so much so that the precipitated substance is left in the reaction medium at a concentration less than the minimum weighing limit of

the weighing analytical balance. In simpler words, the precipitate must be so water insoluble that its amount left behind in the solution is negligibly small.

2. The precipitate formed must be free from contamination by any other substance.
3. The presence of any constituent in the system must not hinder the complete formation of the precipitate.
4. The precipitate must be of such nature that it can be easily and rapidly filtered off, washed free of impurities, and then dried.
5. The precipitate must be of known and constant composition – the composition that is to be utilized in the calculations.
6. The weight of the precipitate recorded must be constant.

1.2.2 Electrogravimetry

Electrogravimetry is a mere extension of the technique of gravimetry. In electrogravimetry, the substance to be determined is decomposed by electrolysis and the material/s collected at one of the electrodes or both the electrodes is/are measured. In other words, the precipitation is carried out by electrolytic deposition by applying a required voltage (potential difference) between the two electrodes immersed in a solution of the substance to be determined. The rest of the experimental process is identical to usual gravimetry. Electrogravimetry eliminates the cumbersome time consuming filtration process; however, there must not be any co-precipitation, which usually does not take place.

As an illustration, in the determination of copper content of a substance, say a copper ore, a solution of the substance is prepared from an accurately weighed mass of the substance (ore) and the solution is subjected to electrolysis between two platinum electrodes. The copper deposited platinum electrode is removed, dried, cooled, and reweighed. The difference of the two weights viz. platinum electrode with and without copper deposit, is the deposit weight of copper. Note that three weights are involved in the present assay viz. weight of the sample (copper ore), weight of the platinum electrode, and weight of the platinum electrode along with copper deposit. Usual calculations are followed to have the copper content of the ore.

1.2.3 Gasometry

In gasometry, the purity of a substance is determined by measuring the volume of a gas that is absorbed or liberated by a given mass of the substance either by heating or by means of chemical reactions. Gasometry is based on the basic principle that one gram molecular weight (mole) of a gas occupies a volume of 22.4 L at STP (Avogadro's law). The chemical equation of the reaction is taken into count for the necessary calculations. For instance, CaCO_3 content of a limestone sample can be determined by strongly heating a small and accurately weighed mass of the sample for the formation of CO_2 , measuring the volume of CO_2 released during the chemical decomposition process, and then relating

the volume of CO_2 to the amount of CaCO_3 by using the chemical equation. The reaction employed is



The reaction states that at STP, 22.4 L CO_2 is liberated by one gram molecular weight of CaCO_3 (or 100 g CaCO_3). Stated otherwise, 1 L CO_2 at STP equals to 4.4643 g CaCO_3 .

A much followed gasometric analysis is the determination of nitrite by its reaction with sulfamic acid ($\text{H}_2\text{NSO}_3\text{H}$). The chemical reaction is:

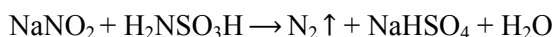

In accordance to the reaction, one gram molecular weight of a nitrite in its reaction with sulfamic acid forms 22.4 L elemental nitrogen at STP. Incidentally, nitrates do not undergo any kind of reaction with sulfamic acid and thus, nitrites can be estimated in the presence of nitrates, a point of much practical significance, since in nature nitrites are almost invariably found along with nitrates. Also of interest to note is the fact that in the present case, the method can be converted to a gravimetric method too in which case the soluble sulfate can be converted to an insoluble precipitate of BaSO_4 by adding BaCl_2 . By doing so, the results of the analysis can also be checked.



In gasometry, much of the ancillary works such as sample preparation, filtration, drying, cooling, preparation and use of a range of chemicals is avoided. By far, the more important advantages of gasometry are no requirement of standard substances, standard solutions, and any indicator.

1.2.4 Titrimetry/Volumetry

Titrimetry, also referred to as volumetry, involves a chemical reaction in which a known mass of the substance to be determined is made to a solution of known volume, and then the entire volume or a part of it as it is convenient and feasible (aliquot), is allowed to react with a standard solution of a second substance with which it readily reacts. The purity of the substance is calculated by simple arithmetic using the principle of stoichiometry *i.e.* mass of the substance to be determined present in the solution, and the volume and concentration of the standard solution of the reacting substance. The standard solution of the reacting substance, referred to as the titrant, is added from a burette, though however not at all times. The process of finding out the volume of the titrant required for completion of the reaction as stated is called a titration. During the course of the titration, the substance present in the titrant reacts with the substance present in the solution that is being determined. A point is reached when the reaction reaches completion. Detection of this point is the most important part of a titrimetric process. This point of completion of the reaction is called the end point of the titration. In analytical chemistry parlance, the end point is more appropriately referred to as the equivalence point. At equivalence point, the volume of the standard solution (titrant) required to react

quantitatively with the mass of the substance present in the solution has just been added. The analyst has to record this volume called the titre value and proceed with the subsequent calculations.

The arrival of the equivalence point is judged by the arrival of a characteristic property of the titrated solution such as its pH, redox potential, conductance, resistance etc, and accordingly the equivalence point of the titration is detected. In most of the commonly used titrations, the arrival of the equivalence point is signaled by a perceptible visual change such as the appearance of a uniquely different colour of the titrated solution which may be due to reasons like the formation or the disappearance of a coloured substance, or the formation of a particular pH, redox potential etc. In most titrations, very small amounts of specific chemicals are added for exhibiting a colour change to help detect the arrival of the equivalence point of the titration. These special purpose chemicals are called 'indicators'. For instance, in acid base titrations, methyl red, phenolphthalein, bromocresol green etc. serve as indicators. In the use of methyl red as the indicator in acid base titration, the change of colour from yellow to red marks the equivalence point, if only the acid is chosen as the titrant added from the burette. Likewise, in the estimation of reducing sugars by cupric reduction method, a redox titration, methylene blue is the frequently used indicator, and the equivalence point colour is the disappearance of the blue colour of cupric copper present in the titrated solution. In the chloride estimation by titration against standard Ag^+ solution, the indicator used is potassium chromate. The point at which the colour of the solution changes from colourless/white to brick red due to the formation of a brick red coloured silver chromate is taken as the equivalence point of the titration.

Indicators are of two kinds - internal or external indicators. Those like methyl red, methylene blue, and potassium chromate are added to the whole chemical system at beginning or just before the arrival of the equivalence point; they are thus internal indicators. External indicators as the term implies are not added to the titration system and find place only externally. Uranyl acetate serves as an external indicator in the determination of soluble zinc by titration against standard potassium hexacyanoferrate (Fe^{2+}). A drop of the titrated solution taken away is tested with the indicator; the formation of a brown colour is taken as the equivalence point of the titration. External indicators are however, much less in use. Some titrations do not need any indicator at all. There are thus cases where the titrant itself is a coloured species and a little excess of it beyond the equivalence point marks the end point of the titration. For instance, in the titration involving ammonium oxalate against potassium permanganate, the first excess of the latter imparts a detectable light purple colour to the solution to serve as the arrival of the equivalence point. In such titrations, specially added indicators are not required. Potassium permanganate serves as the titrant and an indicator as well, of course, a self indicator.

Depending on the nature of the titrant and the titre, titrimetry may be of various types such as

1. Acid base titrimetry which involves titration of an acid of unknown strength against a standard base or *vice versa* e.g. NaOH vs HCl and $\text{H}_2\text{C}_2\text{O}_4$ (oxalic acid), and $\text{Na}_2\text{B}_4\text{O}_7$ (borax) vs HCl. Such titrations are referred to as neutralization titrations (acidimetry and alkalimetry).
2. Oxidation reduction titrimetry which involves titration of an oxidizing agent of unknown strength against a standard reducing agent or *vice versa* e.g. $\text{K}_2\text{Cr}_2\text{O}_7$ vs. $\text{Na}_2\text{S}_2\text{O}_3$ and KMnO_4 vs $(\text{NH}_4)_2\text{C}_2\text{O}_4$ (ammonium oxalate).
3. Precipitation titrimetry where the reacting substance and the standard solution react to form a precipitate or a sparingly soluble compound as the main reaction product e.g. AgNO_3 against NaCl.
4. Complexometric titrimetry where the reacting substance and the standard solution react to form a soluble but only a very slightly dissociated complex substance e.g. EDTA ($\text{H}_2\text{Na}_2\text{Y}$ form) against soluble metal cations, particularly the divalent ones viz. Ca^{2+} , Mg^{2+} , Sn^{2+} , Co^{2+} , Ni^{2+} etc.

Also, there are nonindicator titrimetric cases where a change in a physical property is utilized to mark the arrival of the equivalence point. The examples include potentiometric, conductometric, amperometric, and absorptionmetric titrations.

1.2.5 Turbidimetry and Nephelometry

Turbidimetry and nephelometry are optical methods of analysis based upon the principle of transmission and scattering of light by the insoluble particles of a substance or their small clumps or aggregates which remain in a state of fairly stable suspension. The insoluble particles or their small clumps or aggregates that remain in a state of suspension constitute the dispersed phase of the system. Very minute aggregates of freshly formed insoluble BaSO_4 particles present in a state of stable suspension is an example of one such dispersed phase. The optical properties like reflection, refraction, transmission, and scattering of radiation incident upon the suspension depend upon the concentration of the dispersed phase *i.e.* BaSO_4 . When monochromatic light falls upon such a suspension, a part of the incident radiation is dissipated by absorption, reflection, and refraction, while the rest is transmitted. The extent of transmission *i.e.* the intensity of the transmitted radiation is a function of the concentration of the dispersed phase. To be more precise, the intensity of the transmitted light decreases as the concentration of the dispersed phase increases. In turbidimetric analysis, this relationship is established, preferably graphically, with the help of known concentrations of the dispersed phase, and the relationship so established is used to determine the unknown concentration of the dispersed phase present in an identically prepared suspension.

Nephelometry is only marginally different from turbidimetry. If the suspension so stated is viewed at right angles to the direction of the incident radiation, the system appears opalescent and the radiation is diffused *i.e.* scattered. The intensity of the scattered radiation becomes a function of the concentration of the dispersed phase. The intensity so stated of a series of known concentrations of the dispersed phase is measured and a linear relationship between the two is established graphically. This established linear relationship is used to find out the unknown concentration of an identically treated dispersed phase.

The widest use of turbidimetry and nephelometry is made use of in the determination of soluble sulfate. Soluble sulfate is converted to insoluble sulfate by adding soluble barium (usually BaCl_2) and a turbid or cloudy suspension of BaSO_4 is obtained. To stabilize the suspension, stabilizers like gum acacia or glycerol-ethanol mixed solution is used. A calibration curve with the help of known concentration of soluble sulfate is a prerequisite of the estimation procedure. Analysis by turbidimetry and nephelometry involve the use of optical instruments turbidimeter and nephelometer, respectively. Visual photoelectric colorimeter, preferably with the use of a blue filter, may also be used as a turbidimeter. In nephelometry, the design of the instrument must be such that the source radiation enters the sides of the cuvettes containing the suspension at right angles; to prevent the entry from other angles, the bottom of the cuvettes is made opaque. The results of turbidimetry and nephelometry are empirical and therefore, construction of the calibration curve is recommended for every day analysis owing to uncertainties in the reproducibility of results. Besides, for reproducible and reliable results, the turbidimetric analysis must be carried out in perfectly identical and alike conditions with not even minor variations with regard to time of the reaction, time of shaking or agitation, time allowed to stand, concentration and amounts of the reagents added, temperature of experimentation, and so on.

1.2.6 Colorimetry and Spectrophotometry

Colorimetry and spectrophotometry are analytical tools based upon the interaction of an incident electromagnetic radiation with matter. The interaction so stated may be made quantitative and this quantification enables colorimetry and spectrophotometry to be a very simple and yet versatile and sensitive analytical tool for the determination of a wide ranging substances. Colorimetry and spectrophotometry are of immense significance in analytical agricultural chemistry. A typical colorimetric exercise is the determination of soil phosphorus by the reaction between *orthophosphate* with specific colour forming agents *viz.* ammonium molybdate, and ammonium *metavanadate*, and measuring the intensity of the colour as a direct function of the amount of soluble phosphorus in the soil. Flame photometry, extensively used for the determination of potassium, a major plant nutrient, in soil, plant and water, is a kind of spectrophotometry. Similarly, the much sensitive atomic absorption spectrophotometry used for the determination of the micronutrient cations *viz.* iron, copper, manganese, and zinc, and

heavy metals viz. cadmium and mercury, is another kind of spectrophotometry. The subject of colorimetry and spectrophotometry owing to their enormous practical significance, is dealt in a separate Chapter.

1.2.7 Electrochemical Methods

Electrochemical methods, though not in large scale use in routine analytical laboratories, serve the limited choice reliable methods in many cases. Electrical methods involve the measurement of electrical parameters viz. current, voltage (potential difference), resistance or a combination of them in relation to the concentration of a substance in a solution. Electrochemical methods include voltametry, coulometry (measurement of current and time required to complete an electrochemical reaction), potentiometry (measurement of the potential of an electrode in equilibrium with the ion to be determined), and conductometry. Electrochemical methods are of particular use in titrimetry, where the equivalence or the end point of a titration is correctly judged by the required volume of the titrant in effecting the desired change of the selected electrical property.

The titrations involving addition of the titrant to the solution during the course of the titration causes a continuous change in

1. potential difference between an indicator electrode and a reference electrode. A titration in which the end point is detected by measuring this potential difference is referred to as 'potentiometric titration',
2. resistance or conductance of the solution as the titration continues. A titration in which the end point is detected by measuring this conductance is referred to as 'conductometric titration',
3. diffusion controlled limiting current between an indicator electrode and a reference electrode upon maintaining a fixed potential between the two electrodes. Such a titration involving the limiting current is referred to as 'amperometric titration'.

Mention must be made also of polarography. Polarography is essentially an extension of 'voltametry', the study of the applied potential versus current relationship during electrolysis carried out in a cell where one electrode is of relatively large surface area, while the other one is of much smaller surface area (referred to as the microelectrode). The influence of voltage change on the current flowing in the cell in the case is the point of study. The microelectrode is usually made of some inert, nonreactive, conducting materials such as carbon, gold, and platinum. If however, the microelectrode is a dropping mercury electrode, the special case of voltametry is referred as polarography. The instrument is called a Polarograph. The autorecorded graphical relationship depicting the polarization of the dropping mercury electrode is called a polarogram.

Amperometry, another electrochemical method, is a little away from voltametry. During the course of a titration, the concentration of the reactant decreases, while that of

the titrant increases. The concentrations of the products of the reaction also increase progressively. If any of these can carry out reduction or oxidation at a microelectrode, the particular voltametric or polarographic process may be employed to follow up the course of the titration and to provide a means of locating the equivalence point volume. Such kind of titration is referred to as an amperometric titration. Amperometric results are subject to less error and thus more reliable, in comparison to those from voltametric and polarographic ones.

1.2.8 Chromatographic Methods

Chromatography is essentially a method of separation rather than analysis. Chromatography since its discovery by Michael Tswett, a botanist, in 1906 in Warsaw, has undergone countless improvements and is now an inseparable component of analytical chemistry. Chromatography enables the analyst to separate a particular substance from a myriad of thousands of similar substances. Many chromatographic tools available now have added the analysis component also in the same instrumentation setup and made the technique a very powerful and versatile tool for separation of substances followed by quantitative assay.

Different substances have different characteristic properties like adsorption, electrical charge, polarity, solubility, size of the molecules, colloidal behavior etc. In chromatography, these differences in properties are exploited for the separation of the substances present in a sample. There are two phases in a chromatographic setup viz. a stationary phase, and a mobile phase. Each phase may be of gas or liquid or even a solid. The mixture of the substances to be separated into individual components is dissolved in or adsorbed over the inert nonreactive stationary phase. And then, the mobile phase (usually a gas or a liquid or a supercritical liquid) is made to sweep or forcibly run over the stationary phase. A substance which is more soluble in the stationary phase or held to the stationary phase more tenaciously covers less distance in moving over the phase at a particular instant of time or takes longer time to travel than another one which is less soluble in the stationary phase or bound less tightly to the phase. Reason? Due to greater solubility or tighter binding of the molecules in/to the stationary phase, the mobile phase is able to displace the particular substance over the stationary phase for shorter distances. As a result of such differential movements, sample components will become separated from each other depending upon their solubility or the degree of binding as they travel through the stationary phase.

Chromatography can be partition chromatography or adsorption chromatography. In either case, chromatographic separations can be carried out using a variety of supports, including immobilized silica on glass plates (thin layer chromatography), volatile gases (gas chromatography), paper (paper chromatography), and liquids which may incorporate hydrophilic insoluble molecules (liquid chromatography).

There are various types of chromatography of which the important ones are mentioned in brief.

1.2.8.1 Adsorption Chromatography

In adsorption chromatography, one of the oldest types of chromatography, the separation of the different constituents is accomplished by the different degrees of adsorptive binding onto surface of the stationary solid phase. In Thin Layer Chromatography (TLC), a type of adsorption chromatography, the silica or alumina gel is the most commonly used stationary phase. The mobile phase is a suitable solvent or a mixture of different solvents. The mixture/mixtures of the constituents to be separated and identified is applied as a circular spot (or band or streak) at the bottom side of the stationary phase (silica gel) placed firmly over a support glass plate called the TLC plate. The spotting is made along a line the two ends of which are marked by pencil. The spotted TLC plate is then put inside a TLC chamber (say, a tall beaker) containing the mobile phase at a height below the line of spotting over the plate. The chamber is covered with an appropriately sized glass plate or similar material and the mobile phase is allowed to sweep the mixture of the components. The mobile phase sweeps away the constituents of the mixture, but at different rates depending upon their different adsorptive binding to the stationary phase. The plate before being overrun is taken out of the TLC chamber and the constituents of the mixture are detected by appropriate detection methods. Application of chromogenic or visualizing reagents and known reference samples of the probable constituents of the mixture are used simultaneously for detection and quantification. Fig. 1.1 illustrates a simplified TLC operation.

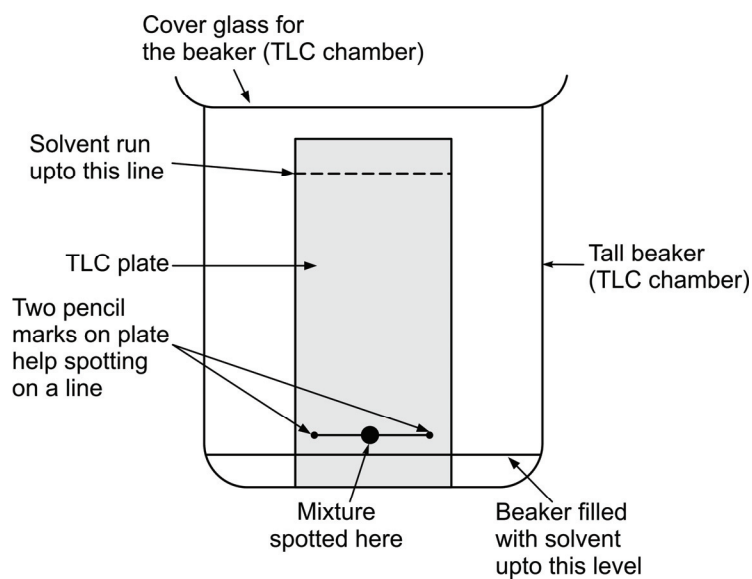

Fig. 1.1 A Thin Layer Chromatogram

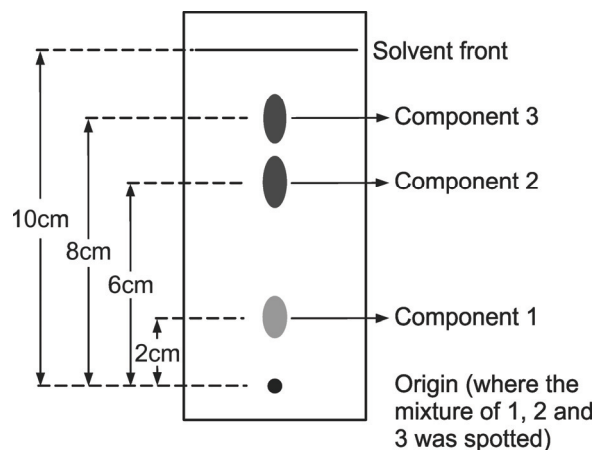

Fig. 1.2 Components of the mixture (referred by different numbers) travel at different rates

The distance to be travelled by a particular component of the mixture is decided by its R_f (Retention Factor). R_f of a substance is calculated as

$$R_f = \frac{\text{Distance travelled by the substance over the stationary phase}}{\text{Distance travelled by the solvent (mobile phase)}}$$

A substance more tightly bound to the stationary phase travels a shorter distance and hence does have a lower R_f . Fig. 1.2 shows that the R_f of the component 1 of the spotted mixture is $\frac{2 \text{ cm}}{10 \text{ cm}} = 0.2$. Likewise, the R_f of the components 2 and 3 are 0.6 and 0.8, respectively. R_f of a substance helps identifying an unknown component.

1.2.8.2 Partition Chromatography

Partition chromatography utilizes a thin film formed on the surface of a solid support by a liquid stationary phase. Paper Chromatography is a widely used type of partition chromatography. In paper chromatography, the mixture of the components to be separated is applied on a paper (nearly inert cellulose with some water content) as a circular spot over a pencil line mark along the bottom side of the paper; a solvent or solvent mixture is allowed to flow through the paper in an upward direction. The solvent or the solvent mixture constitutes the mobile phase that carries the components of the mixture to varying distances as shown in Fig. 1.3. In other words, at any given time, the components of the mixture separate out at different points depending upon the solubility in the solvent or the solvent mixture. The colorless solutes on the paper chromatogram are made visible by spraying visualizing reagents. As in the case of Thin Layer Chromatography, the distance travelled by a particular component of the mixture depends upon its R_f (Retention Factor).

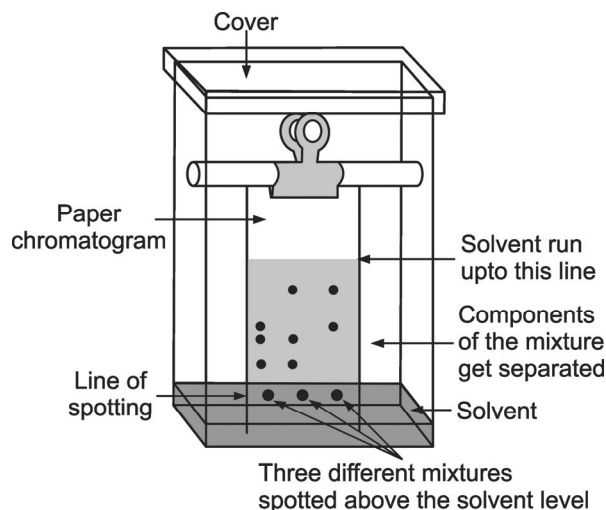

Fig. 1.3 A Paper Chromatogram in running

1.2.8.3 Column Chromatography

Column chromatography is one of the most useful methods for the separation and purification of both solids and liquids. Column chromatography is a solid-liquid chromatographic process in which the stationary phase is a solid and the mobile phase is a liquid. Different substances have different degrees of adsorptive binding to the adsorbent (the stationary phase) and this principle is utilized in the separation of different substances by column chromatography. Routinely employed adsorbents in column chromatography are silica, alumina, calcium carbonate, calcium phosphate, magnesia, and starch. The selection of solvent/solvent mixture as the mobile phase is based upon both the nature of the substances to be separated, and the adsorbent to be used. The rate at which the components of the mixture are separated depends upon the activity of the adsorbent and polarity of the solvent. If the activity of the adsorbent is very high and polarity of the solvent is very low, then the separation is also very slow; however, a good separation is obtained. On the other hand, if the activity of the adsorbent is low and polarity of the solvent is high, the separation is rapid, but gives only a poor separation *i.e.* the components separated may not be very pure.

For carrying out the process of column chromatography, the adsorbent is made to a slurry with an appropriate liquid. A cylindrical tube, usually a glass column with a stopcock at the bottom, is filled with the slurry. The glass column is plugged at the bottom by a piece of glass wool or cotton pad or porous disc. The mixture to be separated is made to a concentrated solution or suspension in a suitable solvent, poured over the top of the column, and is allowed to pass through the column by adding the solvent. As the mixture moves down through the column, the components of the mixture remain at

different heights depending on their ability for remaining adsorbed. Fig. 1.4 depicts a column chromatographic operation with an alcohol extract of leaf pigments as the mixture to be separated into individual components, and CaCO_3 as the adsorbent. The component most tightly bound to the adsorbent remains at the top and the other less tightly bound ones remain below it. The different components can be desorbed and collected separately by adding more solvent at the top and the process is known as *elution*. The weakly adsorbed components are eluted more rapidly than those that are tightly adsorbed. The different fractions are collected separately. Distillation or evaporation of the solvent from the different fractions gives the pure components.

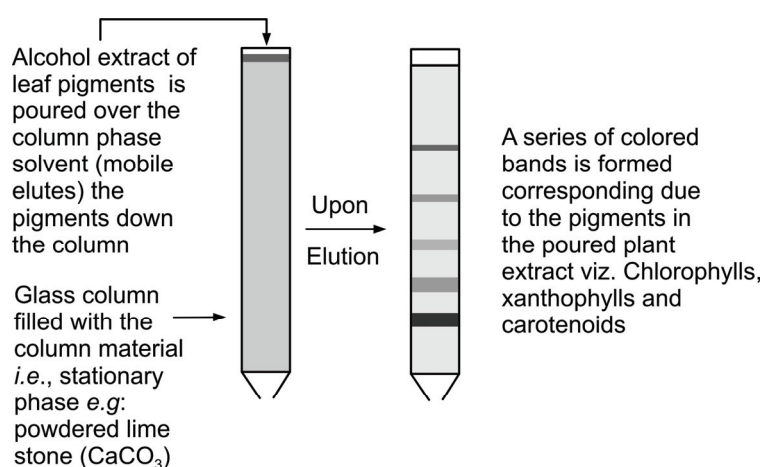

Fig. 1.4 Column chromatography demonstration

1.2.8.4 Ion Exchange Chromatography

Ion exchange chromatography is based upon the principle of ion exchange. If an ion remains adsorbed over the surface of an oppositely charged micelle, another ion with a net greater affinity for the opposite charge can dislodge it on equivalent charge basis. In ion exchange chromatography, a resin (the stationary solid phase) with covalently bound anions or cations onto it is used as the exchanger. Solute ions of the opposite charge in the mobile liquid phase are attracted to the resin by different degrees of electrostatic forces, and thus separate out those already bound, but at different rates and provided they have higher affinity for the opposite charge.

1.2.8.5 Molecular Exclusion Chromatography

Molecular Exclusion Chromatography, also known as gel permeation or gel filtration, does not involve any kind of attractive interaction between the stationary phase and solute/s to be separated. Molecular Exclusion Chromatography in essence is not a separation tool based upon the principle of chromatography. Nevertheless, Molecular Exclusion Chromatography is dealt under chromatography because of its misnomer

terminology. In Molecular Exclusion Chromatography, a glass column is filled with the beads of a highly porous highly hydrated material (such as Sephadex or Bio-Gel). The mixture of substances to be separated is poured over the glass column packed with the beads and is eluted by a solvent (may be water or salt solution). Elution separates the molecules according to their sizes. The pores are normally small and the very large solute molecules are thus simply excluded because of their large sizes; smaller ones however, enter the beads and flow through. The larger ones among them pass through at a rate faster than the smaller ones. In essence, different molecules come out of the column at rates depending on their sizes as shown in Fig. 1.5. The process also known as Gel Filtration is very widely used in Biochemistry and is of routine use in the separation of differently sized macromolecules like proteins.

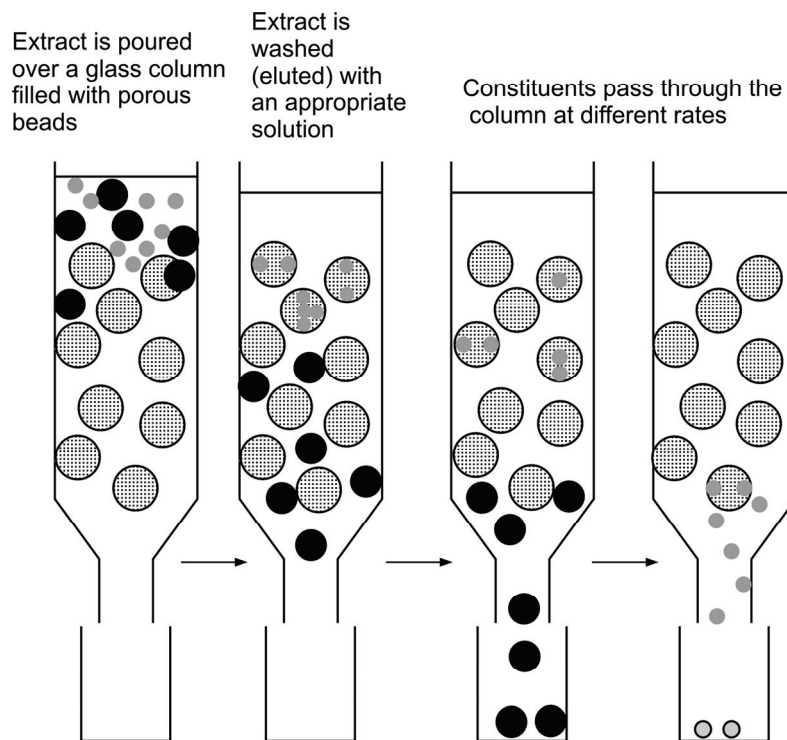

Fig. 1.5 Molecular Exclusion Chromatography. Differently sized macromolecules get separated at different times depending upon their molecular sizes

1.2.8.6 Affinity Chromatography

Affinity chromatography utilizes the specific interaction between one kind of solute molecules and a second one immobilized on a stationary phase. For example, the immobilized molecule may be an antibody to some specific protein. When solute containing a mixture of proteins is passed by this molecule, only the specific protein

reacts to this antibody binding it to the stationary phase. This attached protein is later extracted (detached) by changing the ionic strength or pH. Affinity Chromatography is used more in immunological laboratories.

1.2.8.7 Reverse Phase Chromatography

Reverse phase chromatography involves a hydrophobic low polarity stationary phase which is chemically bonded to an inert solid such as silica. The separation is essentially an extraction operation and is useful for separating non-volatile components.

1.2.8.8 Gas Liquid Chromatography (GLC)

Gas Chromatography is an analytical technique in which the various individual constituents present in the vapourised state of a mixture are separated and fractionated as a consequence of their partition between a mobile gaseous phase and a stationary or fixed or immobile phase placed in a column, followed by determination of one or more of the constituents of interest. Retention of the constituents over the stationary phase is different and is determined by their different degrees of interactions with the same phase. Gas Chromatography is thus essentially a partition chromatography, and the partition of the constituents so stated takes place between (1) a gas and a solid, and (2) a gas and a liquid. Accordingly, Gas Chromatography is of two kinds.

1. Gas Solid Chromatography (GSC) in which the stationary phase is made up of a solid material such as granular silica.
2. Gas Liquid Chromatography (GLC) in which the stationary phase is a nonvolatile liquid used in the form of a thin layer usually held on a finely divided nonreactive inert solid support.

Due to low resolution of the constituents to be separated, GSC is much less in use in comparison to GLC. GLC is now in extensive use in the determination of pesticides, pharmaceuticals, forensic samples and in pollution control, biochemistry, and medical and diagnostic laboratories where very high accuracy and sensitivity are required. GLC thus needs be dealt in greater details in comparison to the other kinds of chromatography. To start with, it is appropriate to describe in brief the two phases of GLC viz. the mobile and the stationary phase.

The mobile phase (Carrier gas)

The mobile phase of GLC comprises the carrier gas. The gas is supplied from a high pressure gas cylinder used as the reservoir. The choice of the carrier gas depends principally upon the type of the detector used in the instrumentation. Streaming of the gas often contains a molecular sieve to filter off water and other impurities, present in the gas if any. The flow of the gas through the column is controlled by a two-stage pressure regulator at the gas cylinder and a flow controller. The pressure at the inlet of the column is greater than the pressure at its outlet. This pressure difference helps force the mobile phase through the column. The commonly used carrier gases are nitrogen, helium, argon,

carbon dioxide, and hydrogen. Hydrogen however, is in less use due its explosion hazard. The major requirements of a carrier gas are

1. the gas must be chemically inert.
2. the gas must allow the detector to respond as much as possible, and
3. the gas should be easily available, pure, and cheap.

The stationery phase

Some of the very commonly used materials used as the stationery phase in GLC which are in fact liquids are furnished in Table 1.1.

Table 1.1 Commonly used liquids as the stationery phase in Gas Liquid Chromatography

Stationery phase	Commonly referred to as	Maximum temperature	Usual applications
Polydimethylsiloxane	OV-1 SE-30	350 ⁰ C	General purpose nonpolar phase suitable for hydrocarbons, polynuclear aromatics, pentachlorobenzenes (PCBs)
5% Phenylpolydimethyl-siloxane	OV-3 SE-32	350 ⁰ C	Methyl esters of fatty acids, alkaloids, drugs, halogenated substances
50% Phenylpolydimethyl-siloxane	OV-17	250 ⁰ C	Pesticides, sterols, glycols, drugs
50% Trifluoropropylpolydimethyl-siloxane	OV-210	200 ⁰ C	Alkylbenzenes, chlorinated aromatics, nitroaromatics
Polyethyleneglycol (PEG)	Carbowax 20 M	250 ⁰ C	Free fatty acids, essential oils, alcohols, ethers, glycols
50% Cyanopropylpolydimethyl-siloxane	OV-275	240 ⁰ C	Polyunsaturated fatty acids, free acids, rosin acids, alcohols, ethers, glycols

The major requirements of the liquid materials to be selected as the stationery phase in GLC are

1. low vapour pressure,
2. thermal stability,
3. low viscosity, and
4. high selectivity for the constituent/s to be assayed.

Instrumentation

There are four essential component parts in a Gas Liquid Chromatograph. They are

- (i) Injection Port
- (ii) Column
- (iii) Detector and
- (iv) Display device.

Each of these parts is described in brief.

- 1. Injection Port:** Analysis by GLC commences with introducing a small amount of the sample (usually 0.1 to 10 μL taken in a micro syringe) into the Injection Port of the instrument. The port is made of a heavy mass and contains a pliable septum through which the sample is injected. The sample solution must be drawn into the syringe a number of times to remove air bubble, if any. The solid samples to be analyzed must be dissolved in solvents before injection. Depending upon the amount of the constituent of interest present in the sample, it however, may be necessary to extract the constituent from the sample and concentrate the extract before its injection into the chromatograph. Also, depending upon the nature of the other substances, co-extractives, and impurities present in the sample or the extract, it may be necessary to clean-up the sample solution or the extract, in case, these substances interfere in the separation and subsequent detection of the constituents of interest in the chromatographic process. The injection of gas sample requires a gas tight syringe (usually 0.1 to 10 μL capacity). Prior to injecting the sample, the port is heated to a temperature for instantaneous vapourisation of the injected sample, taking care not to thermally degrade the constituent/s of interest. Samples which cannot be vapourised must be avoided by all means. To prevent condensation of the vapourised constituents, the Injection Port must be maintained at a constant temperature - higher than that of the column - and must be thermostat controlled. The constituent/s in the injected sample upon being vapourised meet/s the carrier gas stream (the mobile phase) and the two find their way to the Column.
- 2. Column:** The Column which houses the stationery phase (of course a liquid) fixed over an inert solid support is the heart of a gas chromatograph. Within the column only, the individual constituents present in the sample are separated from each other. Most GLC columns are made of a heat resistant glass or a synthetic polymer or a metal (copper or stainless steel) tubing. A metal tubing is certainly a better choice for it is not fragile and can be more easily wound into a coil, thus saving space, if only the constituents to be analyzed does not react with the metal. The columns can be packed or capillary (open tubular) columns. The capillary columns - more efficient than the packed columns - are either wall coated open tubular (WCOT) or support coated open tubular (SCOT) types. In wall coated capillary columns, the inner walls of a capillary tube are lined with a thin layer of the liquid stationery phase, while in support coated capillary columns, the inner wall of the capillary is lined with a thin layer of the support material such as diatomaceous earth, over which the liquid stationary phase is attached by adsorption. WCOT columns are generally more effective than SCOT columns. In packed columns, the solid support material is a porous nonreactive material of siliceous origin such as diatomaceous earth or clay. The support material may be powdered or somewhat finely granulated to reduce the obvious impact of the turbulence of the gas flowing through the column. The support material should absorb the liquid on its surface in the form of a thin, uniform film with a loading of nearly

50% (w/w). Column packing is done by mixing the liquid and solid support prior to filling a tube (length 1.5 to 30 m and about 2 to 4 mm internal diameter) with the packing material. Fig. 1.6 depicts a typically long and coiled GLC column. Fig. 1.7 depicts the liquid stationary phase adsorbed over an inert solid support within the GLC column as the mobile phase runs over the stationary phase.



Fig. 1.6 A typically long GLC column (1 to 30 m) made into a coil

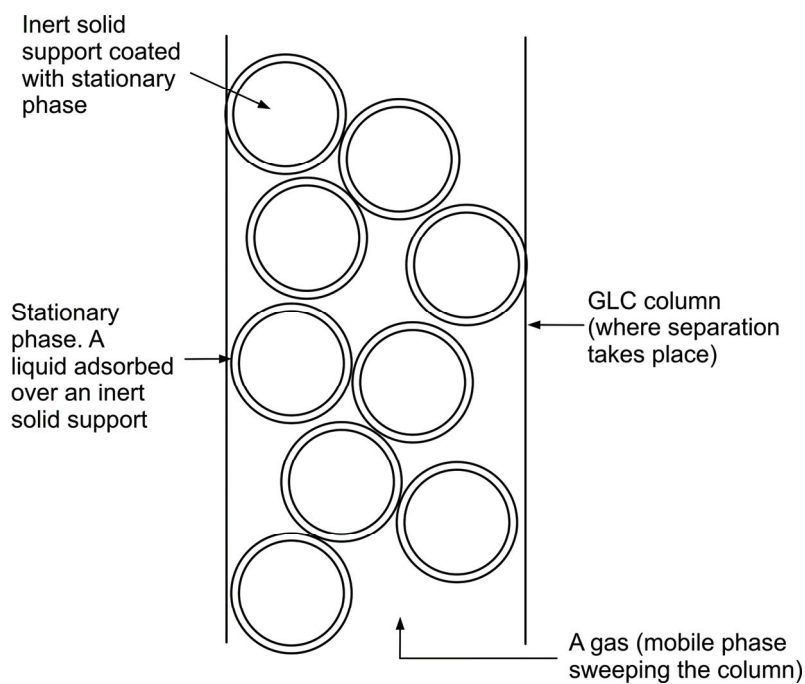

Fig. 1.7 GLC - Liquid stationary phase adsorbed over an inert solid support

The vaporized constituents of the sample are swept by the carrier gas over the column where they distribute themselves between the gas (mobile) and the liquid (stationary) phases. The process of sweeping is called elution. The velocity of the constituents of the mixture as they pass through the column is determined by their respective affinities for the liquid stationary phase accommodated in the column. The partial pressure of a constituent's vapour in the gaseous phase depends upon its solubility in the stationary liquid phase. In any case, each compound distributes itself between the phases to different extents and therefore emerges from the column at a different time. The constituents which dissolve in the liquid phase more readily travel through the column at a slower rate and thus require more time for emerging out from the column. Obviously, the volatile constituents come out of the column much early. The precise time required by a constituent of a mixture of a number of them to move out of the column after running through it and reach the detector is a characteristic of the constituent under given conditions and is referred to as its Retention Time (R_t). Retention time of a constituent however, is not an absolute property of it and depends upon various operating conditions such as

- (i) length and packing of the column
- (ii) nature and flow rate of the carrier gas and
- (iii) temperature of the column

Nevertheless, the ratio of the retention time of one constituent to that of another does not vary much. If the chromatograph is therefore calibrated under the same and identical conditions, the Retention time of a constituent can be used to identify an unknown constituent with the help of known standards. Retention volume (R_v) of a constituent on the other hand is the volume of the gas required to sweep the former to run through the column to reach the detector. The Retention time of a constituent multiplied by the flow rate of the carrier gas is taken as a measure of the Retention volume of the constituent. For GLC to be quantitative, there must be adequate control of the flow of the carrier gas. Regulated carrier gas flow is maintained by flow meter attached to the gas cylinder. The column temperature must also be controlled. For the best results, the column temperature must be controlled within one tenth of a $^{\circ}\text{C}$. The optimum column temperature is to be fixed depending upon the boiling points of the constituents present in the injected sample. As a very general rule, a temperature slightly above the average boiling point of the constituents of the sample results in a retention time of 2 to 30 minutes. A temperature that is just sufficient gives good resolution of the constituents, but requires higher retention times. If a sample has a wide boiling range, a temperature programming in the instrumentation may be desirable, with the column temperature being progressively increased (either continuously or in steps) as separation of the constituents continues within the column. For temperature control, the column is mounted in a thermostat controlled oven.

3. **Detector:** The constituents of the mixture after running through the column exit out and reach the detector of the instrument. The detector works by responding to a change in the chemical or physical nature of the carrier gas leaving the column, and produces an electrical output the magnitude of which depends in part upon the partial pressure of the constituent in the gas. This output the magnitude of which is proportional to the amount or concentration of the constituent in the injected sample is measured and recorded.

There are several kinds of detectors and the particular one is to be selected depending upon the nature of the constituents to be separated or quantified or both. Most common among the GLC detectors are Flame Ionization Detector (FID), Thermal Conductivity Detector (TCD), and Electron Capture Detector (ECD). They are described in brief.

Flame Ionization Detector (FID): FID is the most common among the GLC detectors. The detector is universal in application and can detect almost every organic compound. For detection and quantification, the constituents of the sample after they come out of the chromatograph's column depending upon their retention times are burnt in a flame when different ions are formed. The ions so formed are collected at the electrodes when a current is produced. The magnitude of the current is measured, usually after amplification, and is related to the amount or concentration of the constituent present in the injected sample. The sensitivity of FID is far greater than that of thermal conductivity detector (TCD) - to the extent of about 1000 times or higher. The degree of linearity between the detector response and the amount or concentration of the constituents in the injected sample is much higher than that in TCD. However, during the process of assay, the injected sample is destroyed (destructive) and can't be reused, a major disadvantage of FID.

Thermal Conductivity Detector (TCD): TCD is also a very widely used detector in GLC. TCD is also universal in application and can detect almost any organic or inorganic compound. In TCD, the ability of the constituents, after they come out of the chromatograph's column depending upon their retention times, to conduct heat (thermal conductivity) emanating from a hot wire is measured. TCD utilizes the principle of the change in thermal conductivity of the carrier gas (mobile phase) consequent to the presence of a constituent swept away from the GLC column at its respective resolution time. For measurement as stated, TCD is equipped with a Wheatstone bridge. With the use of TCD as the detector, the carrier gas used as the mobile phase should have very low thermal conductivity (such as argon) for the best analysis results. TCD however, is less sensitive than FID. However, unlike in FID, in the use of TCD, the sample is not destroyed (nondestructive), and can be used for other analyses. This is very significant because a sample to be analyzed often happens to be very scarce, especially in crime and forensic laboratories; this option for reuse is a major advantage of the detector.

Electron Capture Detector (ECD): ECD is not universal in application and is especially suitable for the detection of compounds containing halogens (electronegative elements the atoms of which tend to gain electrons) e.g. chlorine. ECD is thus well suited for the determination of organochlorine pesticides, nitrogen and sulfur containing compounds, conjugated carbonyl compounds, peroxides, nitriles, and polynuclear aromatic compounds many of which are potential carcinogens. ECD utilizes the principle of spontaneous decay of radioactive isotopes. A very common such radioactive isotope used in ECD is ^{63}Ni (a β -emitter). Electrons are produced by ionization of the carrier gas (mobile phase) by β particles of the radioactive source. The electrons so produced are captured by the electronegative atoms of the molecules of the constituents once they emerge from the column depending upon their respective retention times. In their (molecules of the constituents of the sample) absence, a steady stream of electrons is produced; these electrons move to the collecting electrode and a current is produced. When the constituent molecules with the help of their electronegative atoms collect some of the electrons, certainly a lesser number of them reach the collecting electrode. The steady current produced is thus reduced. This reduction in current is measured and is related to the amount or concentration of the constituent containing the electronegative atoms in their molecules.

Some of the lesser used GC detectors are

Mass Spectrometer (MS): MS is universal in application (can detect almost any organic compound) and utilizes the principle of the difference of 'mass-to-charge' (m/z) ratio of ionized atoms or molecules to separate them from each other and then quantify. GC-MS is getting increasingly popular in modern quality control, plant and food analysis, forensic, biochemical, medical, and environmental quality monitoring laboratories.

Thermoionic detector (TD): TD is especially suitable for nitrogen and phosphorus containing compounds.

Photoionizable detector (PID): PID is especially suitable for organic or inorganic compounds that are ionized by UV irradiation.

- 4. Display system/Recorder:** Usually computer controlled display systems are used and the results are pen recorded on a chart called chromatogram. The chromatogram depicts the recorder response against the time which elapses since the sample has been injected into the instrument. Each constituent of the mixture gives rise to a characteristic peak on the chromatogram. The chromatogram thus depicts several peaks depending upon the number of constituents in the sample. The area under a peak (or the height, though less preferably) represents the amount of the constituent present. A typical GLC chromatogram is shown in Figure 1.8.

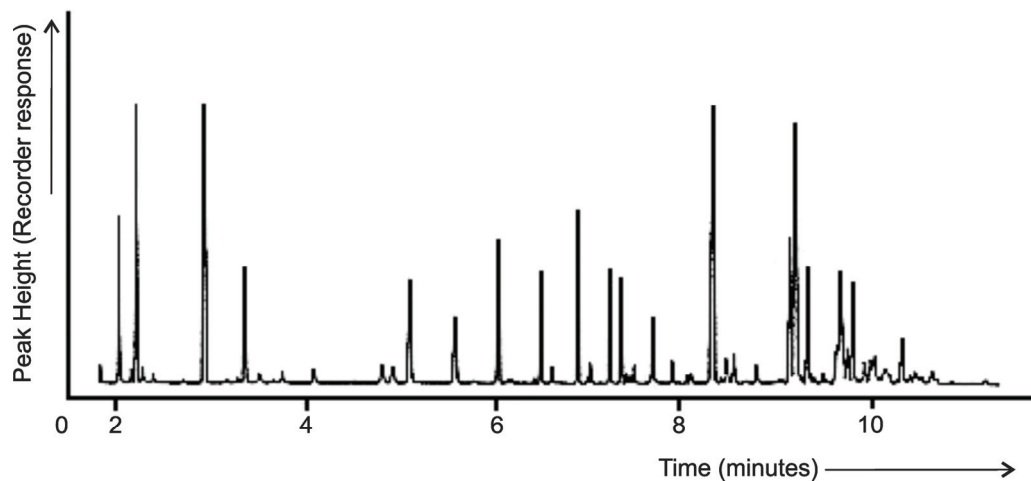

Fig. 1.8 A typical GLC chromatogram showing several peaks. Each peak in the chromatogram represents an individual constituent in the injected sample. Greater and smaller peak areas (or heights) mean greater and smaller amounts of the constituents. x-Axis represents retention time of the components of the mixture that was injected. An increase in the binding of a constituent for the stationary phase causes an increase in retention time (R_t) in the GLC column

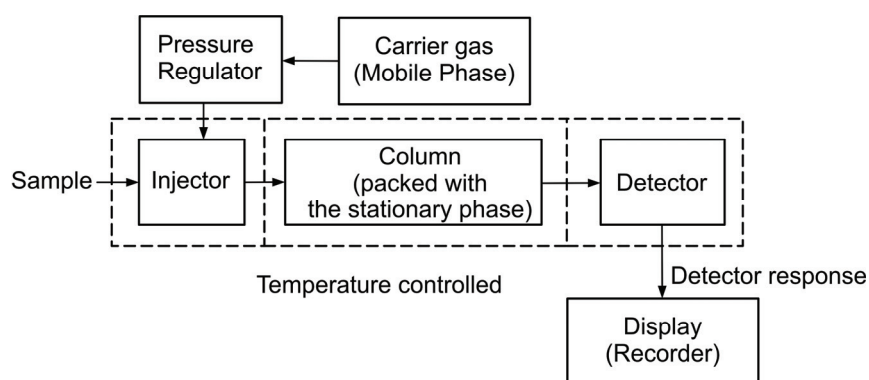

Fig. 1.9 Block diagram of a Gas Liquid Chromatograph

Fig.1.9 depicts a simplified block diagram of a Gas Liquid Chromatograph.

Fig. 1.10 depicts the different components of the instrument with FID as the detector as they are interlinked in the instrument for better comprehension.

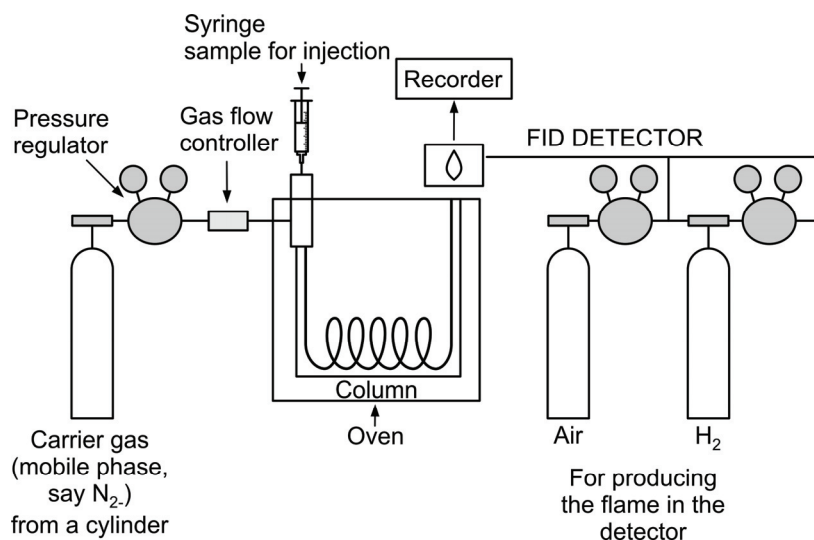

Fig. 1.10 Component parts of a Gas Liquid Chromatograph (with FID as the detector) interlinked as in the instrumentation

Advantages and Disadvantages of Gas Liquid Chromatography

Advantages

1. **Nondestructive analysis:** GLC offers choice of detectors some of which like TCD are nondestructive in nature. The constituents can be recovered from the output gas stream after detection and can be led to more sensitive detectors or for other kinds of analysis.
2. **Derivatization:** GLC offers the option of derivatization of the constituents to be assayed - through reactions such as alkylation (specially acetylation), acylation, and silylation for improved sensitivity of detection.
3. **Choice of columns:** GLC columns are available over a wide range of diameters and lengths (~ 1 to 30 m) along with a wide range of liquid stationary phases. This permits the use of GLC for the analysis of diverse kinds of substances.
4. **High sensitivity:** GLC offers a range of detectors. A judicious selection of one or more of them permits very low detection limits of analysis. Low detection limit in turn requires a very small sample size.
5. **Column reuse:** GLC columns can be reused after reconditioning them.
6. **Speed:** GLC permits securing rapid results of analysis.
7. Precision and reproducibility - High.

Disadvantages

1. Only those compounds that are volatile and those that can be vapourised (either as such or after derivatization) can be analyzed by GLC.
2. GLC is not suitable for thermally unstable compounds, though however, they can be chemically changed to thermally stable derivatives.
3. Gas Liquid Chromatograph is a somewhat costly analytical instrument.

1.2.8.9 High Performance Liquid Chromatography (HPLC)

High Performance Liquid Chromatography (HPLC), once referred to as High Pressure Liquid Chromatography, is an improved kind of liquid chromatography with a liquid as the mobile phase used for the separation, quantification, and purification of the different constituents present in a sample. As in any other chromatographic tool, HPLC also does have two phases - a stationary phase and a mobile phase. In HPLC however, a high pressure provided by a pump, rather than gravity is used to move the liquid mobile phase and along with it, the constituents of the sample, through a densely packed column. The high pressure becomes a necessity because the stationary phase is made of very small sized (in microns) porous particles, making normal run of the constituents through the column very slow. The constituents in the sample have different degrees of affinities and interactions with the stationary phase. When swept over by the mobile phase under pressure, the different constituents in the sample move at different rates. Those that have stronger attachments with the stationary phase pass through the chromatographic column at a rate slower than those which have weaker attachments. Analysis by HPLC commences with introducing the sample in the form of its solution into the instrument through an injector at the end of the chromatographic column. Separation of the constituents of the injected sample occurs as the mobile phase is pumped through the column. At the end of the separation process, the constituents come out (elute) of the column, of course at characteristically different times. The eluted constituents are monitored by an appropriate detector and the output of the detector is displayed by the recorder on a chart paper (chromatogram) or on a computer screen. For collection, storage, and interpretation of the results, integrators and data processing tools are in frequent use.

HPLC is performed principally in two modes viz.

1. Normal phase HPLC and
2. Reverse phase HPLC

Normal phase HPLC uses a polar stationary phase *e.g.* silica, and a nonpolar solvent as the mobile phase *e.g.* hexane, with respect to the constituent/s of interest. Normal phase HPLC is essentially the same as the usual column chromatography. Polar constituents of the sample remain longer in the polar column material (stationary phase) in comparison to the nonpolar ones. The latter thus pass through and come out of the column at an earlier time, while the polar ones emerge later. Though referred to as 'Normal phase HPLC' this

mode is much less in use in comparison to the other one. Reverse phase HPLC on the other hand, uses a nonpolar stationary phase *e.g.* silica chemically modified to make it nonpolar by attaching to its surface a hydrocarbon chain, and a polar solvent *e.g.* a mixture of water and methanol, with respect to the constituent/s of interest. There shall be strong attraction between the polar constituents of the sample and the polar solvent *e.g.* aqueous methanol. By contrast, the nonpolar constituents associate themselves with the externally attached hydrocarbon side chains of the chemically modified (polar) silica (stationary phase) through *van der Waals* forces. The solubility of the nonpolar constituents in the polar solvent is also very low because of the need to break the hydrogen bonds as they squeeze in between the water and methanol molecules. The nonpolar constituents thus spend longer time in the column, while the polar constituents travel through the column and exit out faster - reverse of the case with normal phase HPLC. For samples with a number of constituents differing in polarity, one commences elution with a predominantly water based mobile phase and then adds organic solvent as elution continues. The organic solvent increases the solvent strength and gradually elutes the constituents that are more nonpolar and thus more firmly attached to the nonpolar stationary phase. Reverse phase HPLC can thus be used with considerable ease for nonpolar, polar, ionizable, and ionic molecules, and is thus more common in practical use than Normal phase HPLC - to the extent of 90% of HPLC works.

In addition to these two modes, HPLC is performed in various other modes too. They include among others Ion exchange, Gel filtration (molecular exclusion), and Affinity chromatography in which the separation of the constituents is based on their differences in pH dependent charge, size (molecular weight), and hydrophobicity (polarity), respectively.

HPLC is now in extensive use in separation, purification, and quantification of samples where high sensitivity, accuracy, reproducibility, and rapid results are required. In dealing HPLC in brief, it is appropriate to start with its two phases viz. the mobile and the stationary phase.

The stationary phase

The most widely used stationary phases (column packing materials) used for the separation of different constituents in HPLC are silica based materials. A very popular material is octadecyl (18 C) silica (ODS-silica) which contains a 18 C attachment coated over silica. C1, C2, C4, C6, C8, and C22 coating attachments are also in use. Silica attached to other chemical moieties is also in much use. Next in significance as the column packing material used as stationary phase in HPLC are the polymer based ones. The latter include polystyrenes, polymethacrylates and polyvinyl alcohol. Natural substances such as cellulose, dextrans, agarose, chitosans, and ceramic members like zirconia and hydroxyapatites are also in use for the separation of specific substances. Popular sizes of the porous packing materials (size of the pores on the surface are in Angstrom units) are 1.8, 3.5 and 5 μm . Smaller particle size of the stationary phase

material may improve chromatographic resolution, but requires increased solvent delivery pressure. Further reduction in size of the same with higher solvent flow rate reduces analysis time without any reduction in resolution (Ultra High Pressure Liquid Chromatography).

The mobile phase

A variety of organic solvents either as such or mixed with water for securing varying degrees of polarity are in use as the mobile phase in HPLC. The solvents in common use are methanol, tetrahydrofuran, acetonitrile etc. For securing better separation of the constituents of a mixture, it is certainly easier to vary the polarity of the mobile phase keeping the polarity of the stationary phase unchanged, rather than doing the same in the other way. This also explains why the Reverse phase HPLC is more common in practical use than Normal phase HPLC. For effecting varying polarity and dielectric constant of the mobile phase, inorganic salts are often added to the solvent. The solvents used for the mobile phase and the salts added to them, if any, must be very pure to avoid leading and tailing of the peaks in the chromatogram. The latter may add confusion in interpreting the chromatogram. The solvent used as the mobile phase is added to the packed column from a reservoir that can be an ordinary glass bottle with a tubing connected to the pump inlet.

Instrumentation

There are five essential component parts in the instrumentation of a High Performance Liquid Chromatograph. They are

1. Pump
2. Injector
3. Column
4. Detector and
5. Display device.

These parts are described in brief.

1. *Pump*: In HPLC, a pump is used to push the mobile phase through the densely packed stationary phase held in the column. The pressure applied by the pump runs the mobile phase at a normal flow rate of 0.1 to 2 ml min⁻¹. Typical HPLC pumps can reach a pressure of 4500 to 9000 psi (300 to 600 bar). The pressure applied must be steady for securing stable and reproducible results. The pumps can deliver a constant mobile phase composition (isocratic) or an increasing mobile phase composition (gradient). A common cause for unstable and fluctuating HPLC results is leakage in the pump. For long life of the instrument, and accurate and reproducible results of analysis, the pump requires adequate care and maintenance.
2. *Injector*: Injector introduces the sample solution (normally between 5 to 20 μL) into the flow stream of the instrument. There may be one or more than one injector in the instrument. The injector must be able to withstand the high pressure of the mobile phase. In instruments with manually operated injectors, the analyst loads the sample solutions into the syringes and introduces them into the flowing mobile phase at the beginning of the column which is at high pressure. In many of the instruments currently in the market, the injectors however, are automated. The analyst fills the

sample vials with the sample solution into the autosampler tray (nearly 100 vials); the autosampler measures right sample volumes, injects them into the instrument, and then flushes the injector to be used for the next sample - all done automatically until all the samples of the tray are done. If the sample is a liquid, it can be injected into the instrument as such or after dilution and clarification as required; if the sample is a solid, it must necessarily be made to a solution for the sake of injection into the instrument.

3. *Column*: Column is the heart of HPLC separation, since within the column only, the separation of the different constituents of a sample takes place, the same as in the case of GLC. HPLC columns are commercially available in different lengths and internal diameters, and even filled with the packing materials, with no necessity for column packing by the analyst. The columns may be made of stainless steel (most popular as it can better withstand the applied high pressure) or glass (very popular for biomolecules) or polyether ether ketone (PEEK) (biocompatible and chemically inert to most solvents). Various types of columns are available such as analytical (internal diameter -1 to 4.6 mm, length -15 to 250 mm), preparative (i.d. < 4.6 mm, length 50 to 250 mm), capillary (i.d. -0.1 to 1 mm, varying length) and nano columns (< 100 μm) The right one is to be selected depending upon the type of separation, column packing material, and flow rate of the solvent (the mobile phase). Columns are packed under high pressure so that they are stable during use and can withstand the turbulence caused by the high pressure of the mobile phase. Column temperature is an important aspect in separation by HPLC, because retention of a constituent inside the column is highly temperature dependent. In other words, separation of the constituents depends upon temperature. The results of analysis are gathered from the retention time, retention volume, and height and area of the peaks on the chromatogram. The results therefore shall be valid only with a stable column temperature. A stable column temperature is maintained by placing it in a thermostat controlled oven or heater block or water bath. Also of significance to stress is the point that much reasoning is required in selecting the column temperature. For instance, some constituents of the mixture may get crystallized at the column temperature, while some others may get decomposed and denatured. Many enzymes, antibodies, and antigens get denatured even at the room temperature. The crystallized and decomposed constituents can't be separated in the column.
4. *Detector*: The detectors monitor the concentrations or the amounts of the constituents of the sample as they complete their run through the column upon being swept away (eluted) by the mobile phase delivered under high pressure, and generate a signal. The signal that must be proportional to the concentration of the constituent is amplified before measuring it. The detectors must be sensitive and give reproducible results, and must operate in a way that does not attenuate the separation of the constituents achieved in the column. The detectors in HPLC work on several principles and thus different types of them are in use. Each of them has its own advantages and limitations, and the

correct one is to be selected depending upon the specific analysis to be performed. In general, HPLC detectors are however, neither versatile nor very sensitive in comparison to those of GLC. Four major types of detectors in HPLC are based upon absorbance of Ultra Violet (or UV-Vis) radiation, fluorescence, Refractive Index (R.I.), and Mass Spectrometry.

In UV detection, a beam of UV radiation is directed through a flow cell, while a sensor measures the radiation passing through the flow cell. If a constituent that absorbs UV radiation passes through the flow cell, the amount of the radiation energy falling upon the sensor is changed. The resulting change in the signal is amplified and passed on to the recorder or the data system. An added advantage with UV detection is that a UV spectrum of the constituent may also be obtained; the obtained UV spectrum proves to be useful in the identification of the constituent present in the sample. UV (or UV-Visible) detector is however, suitable only for those compounds which strongly absorb radiation in UV or visible range of the electromagnetic spectrum. These compounds include large organic molecules with conjugated double bonds and transition metal compounds. In Refractive Index detection, the property of a compound to deflect light is utilized. The Refractive index is a measure of the ability of a constituent to deflect light in a flowing mobile phase in a flow cell relative to a static mobile phase contained in a reference flow cell; the degree of deflection is related to the amount of the constituent in the injected sample. The Refractive Index detector is universal in application, but suffers from the defect of being not very sensitive. Fluorescence detector works on the principle of fluorescence exhibited by the constituents of the sample. The detector is very sensitive for detection and quantification, but the scope for application is very limited as only those substances that fluoresce can be measured. A Mass Spectrometer (MS) detector senses a constituent eluted from the HPLC column first by ionizing it, and then measuring its mass and fragmenting the molecule into smaller pieces that are unique to the constituent of the injected sample. An added advantage with detection by using a MS is the possibility to identify the constituent directly from its unique mass spectrum - the finger print of a compound.

5. *Display system*: The output received from a detector is commonly recorded as a series of peaks on a chart paper of the recorder, the same as in GLC; the latter is called the chromatogram. Each peak on the chromatogram represents a constituent present in the injected sample. The time taken by a constituent to pass through the column for eventually reaching the detector is called the Retention time (R_t) as depicted in Fig 1.11. This time is measured from the time the sample is injected into the instrument right upto the point at which the display shows a maximum peak height for the constituent. R_t of a particular constituent in the sample can be used to identify it, provided that the operating conditions such as column temperature, gas flow etc. are kept unaltered, and furthermore, the R_t of the pure constituents secured under the identical operating conditions are identical.

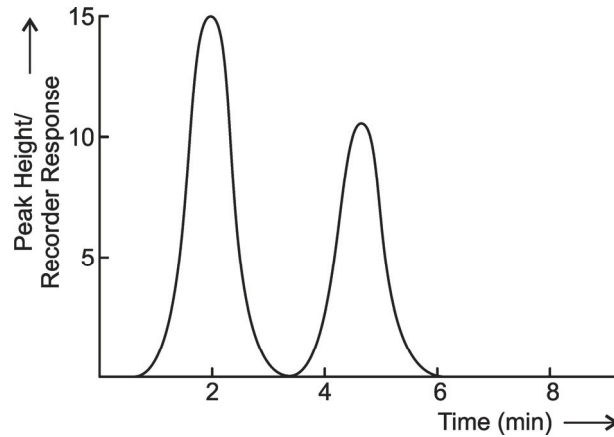

Fig. 1.11 Peaks on a HPLC chromatogram. Greater and smaller peak areas mean greater and smaller amount of a constituent in the sample. Higher R_t represents stronger interaction between the constituent and the stationary phase

The Retention time (R_t) of a particular constituent is not a fixed property, and depends upon

1. Nature of the mobile phase (polarity)
2. Pressure applied and flow rate of the mobile phase
3. Nature of the stationery phase (polarity, particle size, and pore size)
4. Particle size of the stationery phase
5. Column temperature

Retention volume (R_v), also a unique characteristic of a constituent, is defined as the quantity of the mobile phase required to move it through the column and is derived as the product of the flow rate of the mobile phase and its respective R_t . The greater the area (or, less preferably the height) of the characteristic peak, greater is the amount of the constituent. For quantification of the constituent, the peak area is thus taken into count. However, the instrument is to be calibrated with known concentrations of the constituents for establishing the range of linearity between the concentration of a constituent and its peak area on the chromatogram.

In modern instruments, the data acquisition system, interpretation of data, and the results of analysis, and even other aspects starting from sample injection are integrated and computer controlled.

Fig.1.12 depicts a simplified block diagram of a High Performance Liquid Chromatograph.

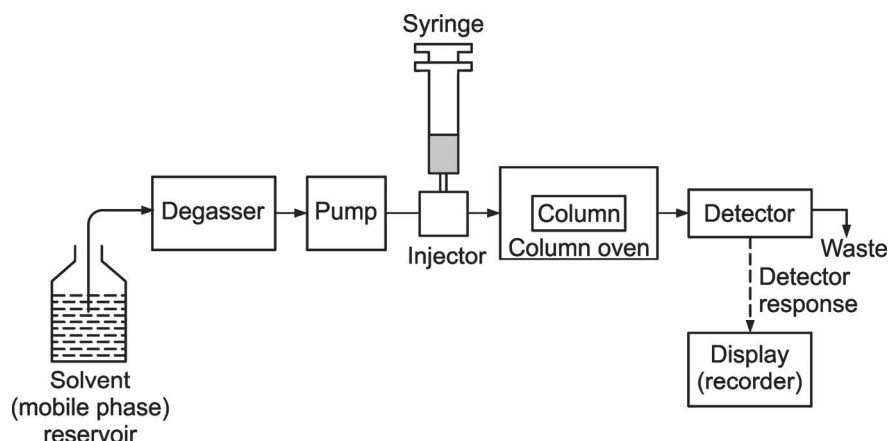

Fig. 1.12 Schematic representation of a High Performance Liquid Chromatograph by a block diagram

Degassing

An important aspect in securing very reliable, reproducible, and sensitive results in HPLC analysis is degassing of the mobile phase *i.e.* removal of the air bubbles. When solvents (methanol, acetonitrile etc.) are in contact with the atmosphere, air gradually gets in depending upon the solubility of its constituents. When the solvents are mixed, the solubility of the air (its constituents, principally nitrogen and oxygen) is less than it is in the same proportion of the pure solvents; this excess air tends to come out of the mixed solution in the form of bubbles. This bubbling out of the dissolved gases from a solvent or solution is described by the term 'outgassing'. It may be mentioned in the context that low pressure (at atmospheric pressure) mixing systems are more prone to bubble formation leading to outgassing anywhere down the flow path. In high-pressure mixing, the pumps pump in only the degassed solvents or mobile-phase mixtures, and due to mixing under pressure, bubbles that might otherwise form at atmospheric pressure remain in solution because of the elevated pressure of the system.

The outgassing process adversely affects the pump (for moving the mobile phase) and the detector of the instrument, and in turn lead to serious complications in HPLC analysis. For instance, the bubbles may modify the flow rate of the solvent by creating 'dead volumes', and may even cause pump failure (effects on the pump); the bubbles may also cause unstable and noisy base lines, and spurious peaks on the chromatogram (effects on the detector). 'Degassing' of the mobile phase thus becomes necessary to overcome all such problems caused by bubble formation.

Boiling of the solvents is the best and the simplest way to expel all the dissolved air and gases. Nevertheless, boiling is never advised because of the volatile loss of the solvents along with the dissolved gases; besides, much time is required to equilibrate the

boiled mobile phase to the ambient temperature. Three commonly used degassing practices are:

1. Helium purging
2. Vacuum degassing
3. Sonication

In degassing of the mobile phase by bubbling with helium, known as helium purging, helium run from its cylinder is bubbled into the mobile phase at which helium dissolves and displaces the dissolved air. Helium is preferred because of its low solubility in most solvents, and its solubility is only marginally affected by temperature. It may appear contradictory to use a gas to degas a solution; however, the unique solubility of helium permits it so. With degassing of the mobile phase by helium purging, a stable baseline with high sensitivity is obtained, especially in instruments that use detectors that are based upon fluorescence, refractive index and absorption of UV radiation. Helium purging removes up to 80% of the dissolved air. Despite the decreased availability of helium, and the availability of built-in vacuum degassing in the instrument, helium purging is still the most widely used degassing method. In vacuum degassing, a vacuum is created during filtration of the mobile phase through a 0.45 or 0.22 μm pore size membrane filter. Vacuum degassing removes 60 to 70% of the dissolved air. Built-in vacuum degassing system is now available in many commercially available instruments. The mobile phase is passed through a porous polymer tubing placed in a vacuum chamber placed inside the instrument. The porosity of the tubing allows expulsion of the gases through the walls, while the liquid is retained inside the tubing. Sonication refers to the act of applying sound or ultrasound waves (frequency > 20 kHz) to a system (in this case the solvents or the mobile phase) for agitation of the articles therein. For degassing by sonication, ultrasonic baths are in use. Sonication is however, not a very effective degassing practice and removes only 20 to 30% of the dissolved air. Sonication is thus inadequate to degas the mobile phase in HPLC and is to be practiced only in combination with other degassing practices. Most manufactures now include degasser as a component part of the instrument; the block diagram of the instrumentation (Fig. 1.11) shows the degasser at a place where it should be. Nevertheless, most HPLC analysts prefer to briefly 'sparge' the mobile phase with helium, and then use the built-in degasser to keep the dissolved gas content at a very low level.

Sample Preparation

Sample preparation is an important aspect in HPLC analysis; it is often not simply dissolving a solid or a liquid sample into a solvent to form a solution for its loading into the syringe so that it can be injected into the instrument for its analysis. Additional processes such as (1) filtration, (2) extraction, and (3) derivatization of the constituents of interest present in the sample often become mandatory. Filtration is required when the sample contains suspended solids, as the latter may corrupt the stationary phase and clog the HPLC column. Filtration is performed by using a pre-column filter (as a part of the

instrument), or when the sample is taken to the sample vial for subsequent injection into the instrument. Extraction is required, if the sample is likely to contaminate the HPLC system or cause blockage by particulate matter, or the constituent of interest is present in the sample at very low level requiring pre-concentration. Sample derivatization becomes necessary, especially for detection purposes. For instance, it may not be possible to detect the constituent of interest present in the sample by UV detection due to not having any chromophore (radiation absorbing group such as nitrate, $-\text{ONO}_2$ and nitro, $-\text{NO}_2$ that absorb at 270 and 210 nm, respectively) in the molecule. Introducing these groups into the molecule by derivatization *i.e.* nitration makes possible to identify these substances by UV detection. Sample derivatization can be done before or after passing through the column, and manually or automatically.

Advantages and Disadvantages of High Performance Liquid Chromatography

Advantages and disadvantages of HPLC are broadly the same as in GLC. However, the instrument in HPLC is more costly, but gives a much better resolution of the constituents of a mixture to be separated. Besides, HPLC can be used for the analysis of more diverse kinds of substances, and in addition, can be run in several other modes such as preparative, ion exchange, and molecular exclusion modes, making the technique more versatile.

1.2.9 Radioactive Methods

Radioactive methods employ unstable radioisotopes of elements such as P^{32} or C^{14} . The nuclei of the atoms of such unstable isotopes undergo spontaneous decay with the emission of α , β , and γ rays in a bid to convert themselves to their nearest stable isotopes. The emitted radiations are assayed by instruments like Geiger Muller Counter or Liquid Scintillation Counter. The quantum (intensity) of the emitted radiation is a definite function of the mass of the radioisotope present in the sample and hence, the amount of the substance containing the radioisotope in the sample can be determined.

The properties which make radioactive isotopes very important analytical tools are

1. the intensity of the emitted radiations are characteristic functions of the mass of the radioactive isotopes,
2. the radioactive isotopes behave exactly the same way as their normal isotopes in all aspects, except the emission of spontaneous radiation *i.e.* radio chemical decay,
3. the methods involving radioactive isotopes are nondestructive.
4. the radioactive methods are very rapid and there is no need for sample preparation and purification.

However, radioactive methods suffer from few defects such as

1. for many elements, suitable isotopes with reasonable half life values are not available,

2. the use of radioactive isotopes and the instruments used for radiochemical assay are under strict regulation by direct control of the Government agencies/various statutory authorities, and the chemists do not have open access to their use.

1.3 Working Out Calculations in Quantitative Analysis

1. A silver ore weighing 0.6528 g upon treatment with a soluble chloride formed a precipitate of AgCl that weighed 0.2277 g. Calculate the per cent silver content of the ore.

Ans: The atomic weight of Ag is 107.868, while the molecular weight of AgCl is 143.321.

$$\therefore 143.321 \text{ AgCl} = 107.868 \text{ g Ag.}$$

$$0.2277 \text{ g AgCl} = \frac{107.868 \times 0.2277}{143.321} \text{ g Ag} = 0.17137 \text{ g Ag}$$

$$\therefore \% \text{ Ag content of the ore is } \frac{0.17137 \times 100}{0.6528} = 26.252$$

2. A limestone (CaCO_3) sample weighing 0.90768 g was treated appropriately so as to form a precipitate of CaC_2O_4 (calcium oxalate). The cooled residue of CaC_2O_4 was found to weigh 0.6254 g. Calculate the per cent Ca and CaCO_3 content of the limestone sample.

Ans: $\text{CaCO}_3 \rightarrow \text{CaC}_2\text{O}_4$

The molecular weights of CaCO_3 and CaC_2O_4 are 100.089 and 128.100, respectively

$$\therefore 100.089 \text{ g CaCO}_3 \text{ forms } 128.100 \text{ g CaC}_2\text{O}_4$$

$$\therefore \text{On the principle of gravimetry, } 128.100 \text{ g CaC}_2\text{O}_4 = 100.089 \text{ g CaCO}_3.$$

$$\therefore 0.6254 \text{ g CaC}_2\text{O}_4 = \frac{100.089 \times 0.6254}{128.100} \text{ g CaCO}_3 = 0.48865 \text{ g CaCO}_3$$

$$\therefore \% \text{ CaCO}_3 \text{ content of the limestone sample is } \frac{0.48865 \times 100}{0.90768} = 53.835$$

$$0.48865 \text{ g CaCO}_3 \text{ contains } \frac{40.08 \times 0.48865}{100.089} \text{ g Ca} = 0.19568 \text{ g Ca}$$

$$\therefore \% \text{ Ca content of the limestone sample is } \frac{0.19568 \times 100}{0.90768} = 21.558$$

3. A marble sample weighing 1.8562 g on strong heating liberated 345 ml CO₂ at STP. Find out the per cent CaCO₃ content of the marble sample.

Ans: CaCO₃ → CaO + CO₂ ↑

The chemical reaction depicts that 1 mole or 100.089 g CaCO₃ liberates 1 mole of CO₂ at STP.

1 mole of CO₂ = 22.4 L CO₂ at STP.

In other words, 22.4 L CO₂ at STP is produced from 100.089 g CaCO₃

$$\therefore 0.345 \text{ L (345 ml) CO}_2 \text{ at STP} = \frac{100.089 \times 0.345}{22.4} \text{ g CaCO}_3 = 1.54159 \text{ g CaCO}_3$$

$$\therefore \% \text{ CaCO}_3 \text{ content of the marble sample is } \frac{1.54159}{1.85620} \times 100 = 83.051$$